



Adhams®

TIMBER TUBE

## About us

Since 2015, our premium brand Adhams has been redefining interiors with high-quality decoration concepts. Now, Adhams has conquered the front row position with pride. It offers hundreds of premium products that bring timeless style to your every space.

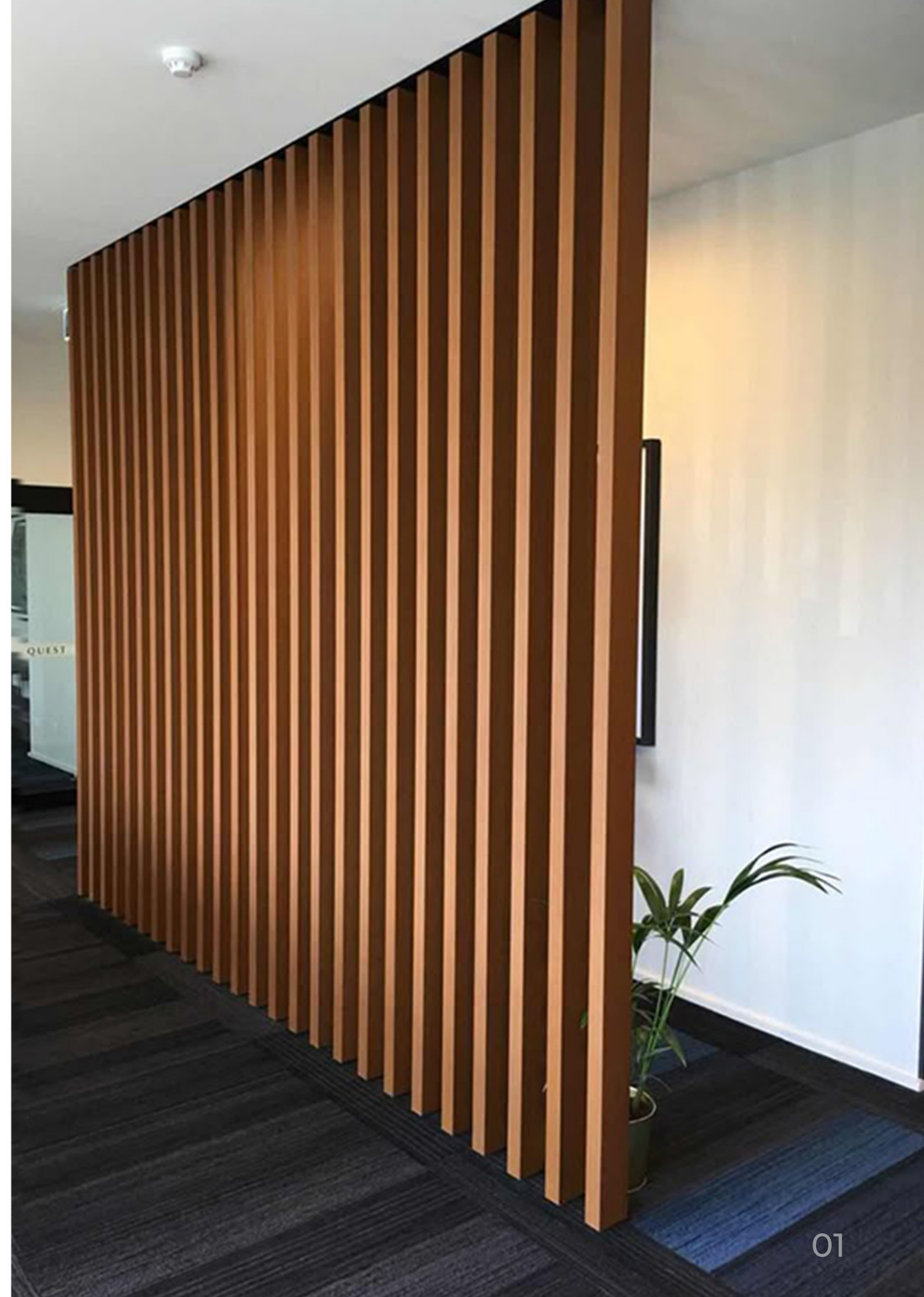

# Why choose ADHAMS ?

## Quality Products:

We ensure the highest quality in our materials, sourced from trusted manufacturers.

## Wide Range of Options:

Our extensive product range caters to diverse styles and requirements.

## Competitive Pricing:

We offer competitive prices without compromising quality, making our products accessible to all.

## Wide Network:

We have hundreds of trusted dealers and can deliver anywhere in India, ensuring wide coverage and accessibility across the country.

## Expert Assistance:

Our knowledgeable staff is always available to help you choose the right materials for your needs.

## Product Features



Eco-Friendly



Easy Installation



Termite Proof



Low Maintenance

# ADHAMS TIMBER TUBES

---

ADHAMS Timber Tube combines the natural elegance of wood with long-lasting strength, bringing warmth and sophistication to modern interiors. Engineered for versatility, it is ideal for ceilings, wall cladding, partitions, baffle ceiling systems, and decorative applications in homes, offices, and commercial spaces. Its lightweight yet sturdy structure ensures easy installation, reduced load, and excellent durability over time. Resistant to moisture, termites, and warping, ADHAMS Timber Tube delivers a premium finish with minimal maintenance—making it the smart choice for stylish, reliable construction and contemporary decor.

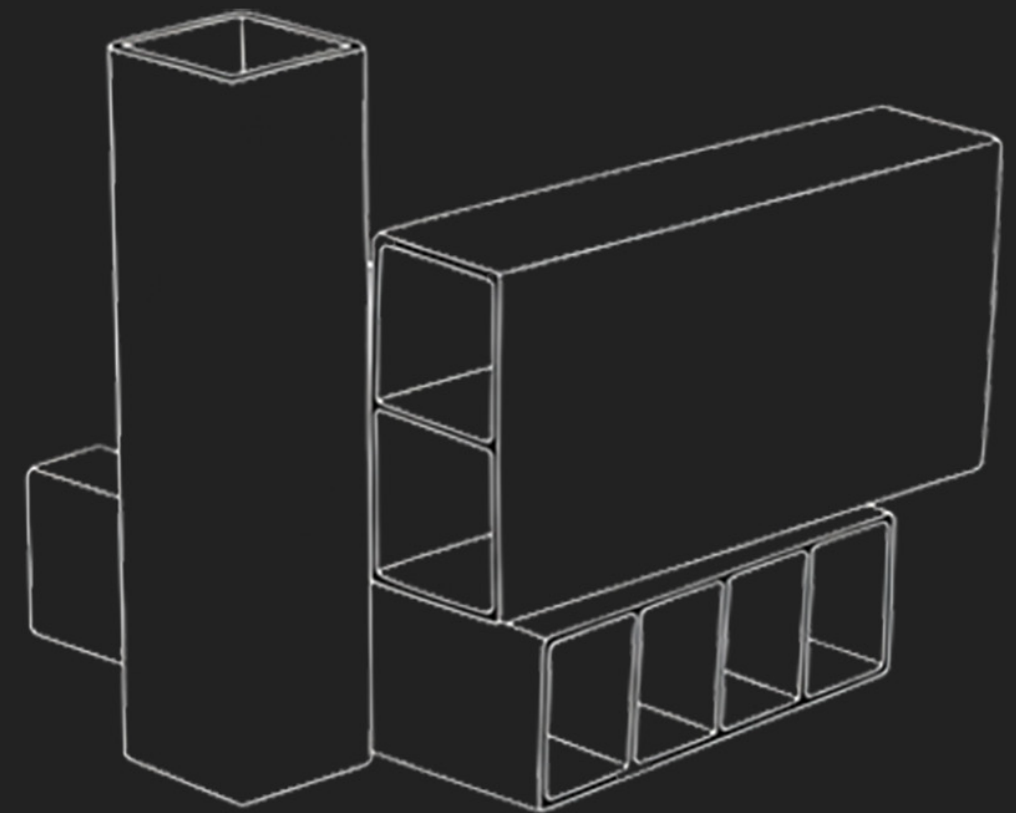

# | TIMBER TUBE 17



**TUBE 5150 -17**

150x50x2900mm

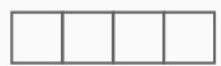

**TUBE 5100 -17**

100x50x2900mm

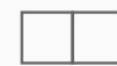

**TUBE 5050 -17**

50x50x2900mm



# | TIMBER TUBE 46



**TUBE 5150 -46**

150x50x2900mm

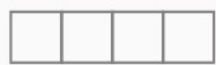

**TUBE 5100 -46**

100x50x2900mm

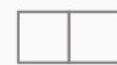

**TUBE 5050 -46**

50x50x2900mm



# | TIMBER TUBE JW



**TUBE 5150 -JW**

150x50x2900mm



**TUBE 5100 -JW**

100x50x2900mm



**TUBE 5050 -JW**

50x50x2900mm



# | Timber Tube Accessories



**Pedestal**  
50x100mm



**Plug**  
50x50mm



**Plug**  
50x100mm



**Pedestal**  
50x150mm



**Plug**  
50x150mm



**Pedestal**  
50x50mm



**Screw**

# | Installation

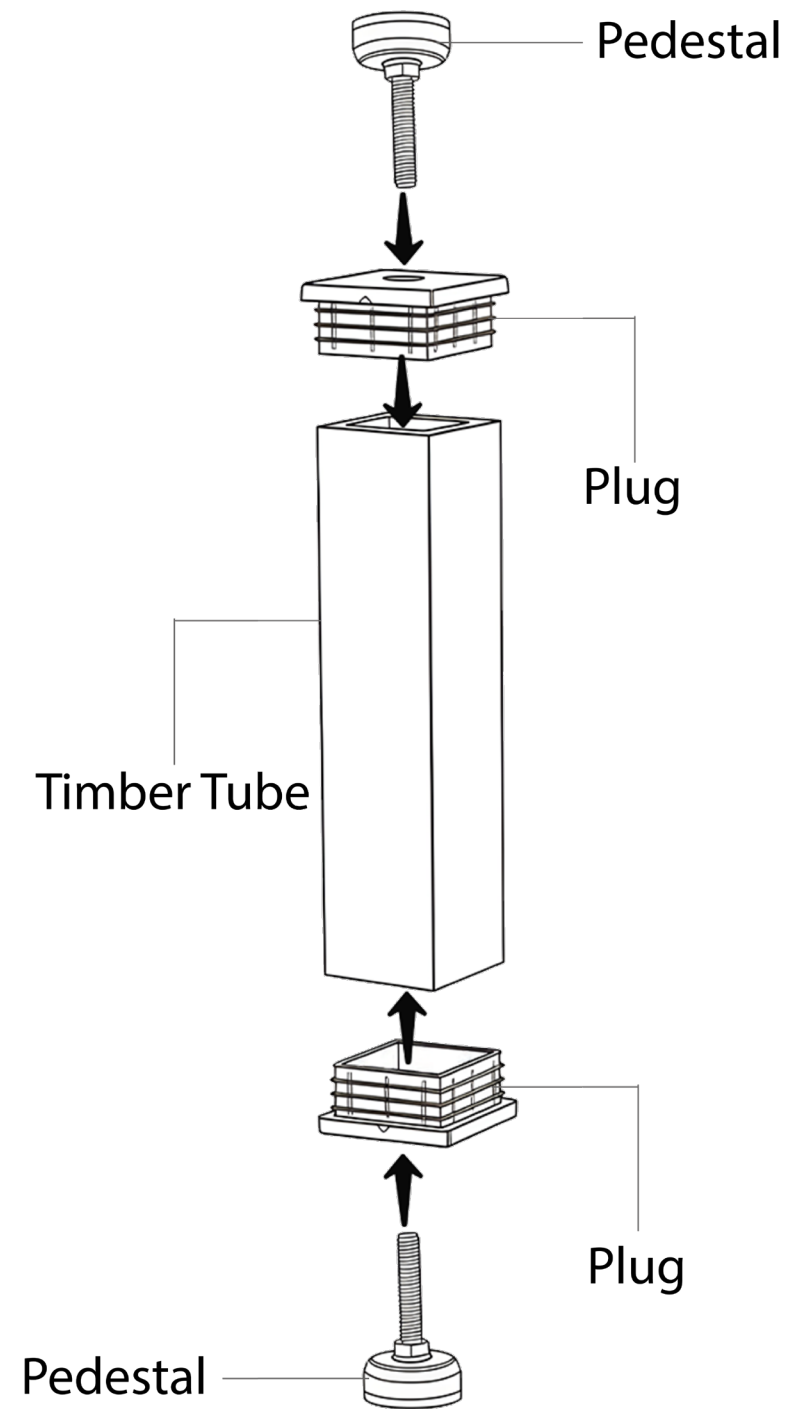
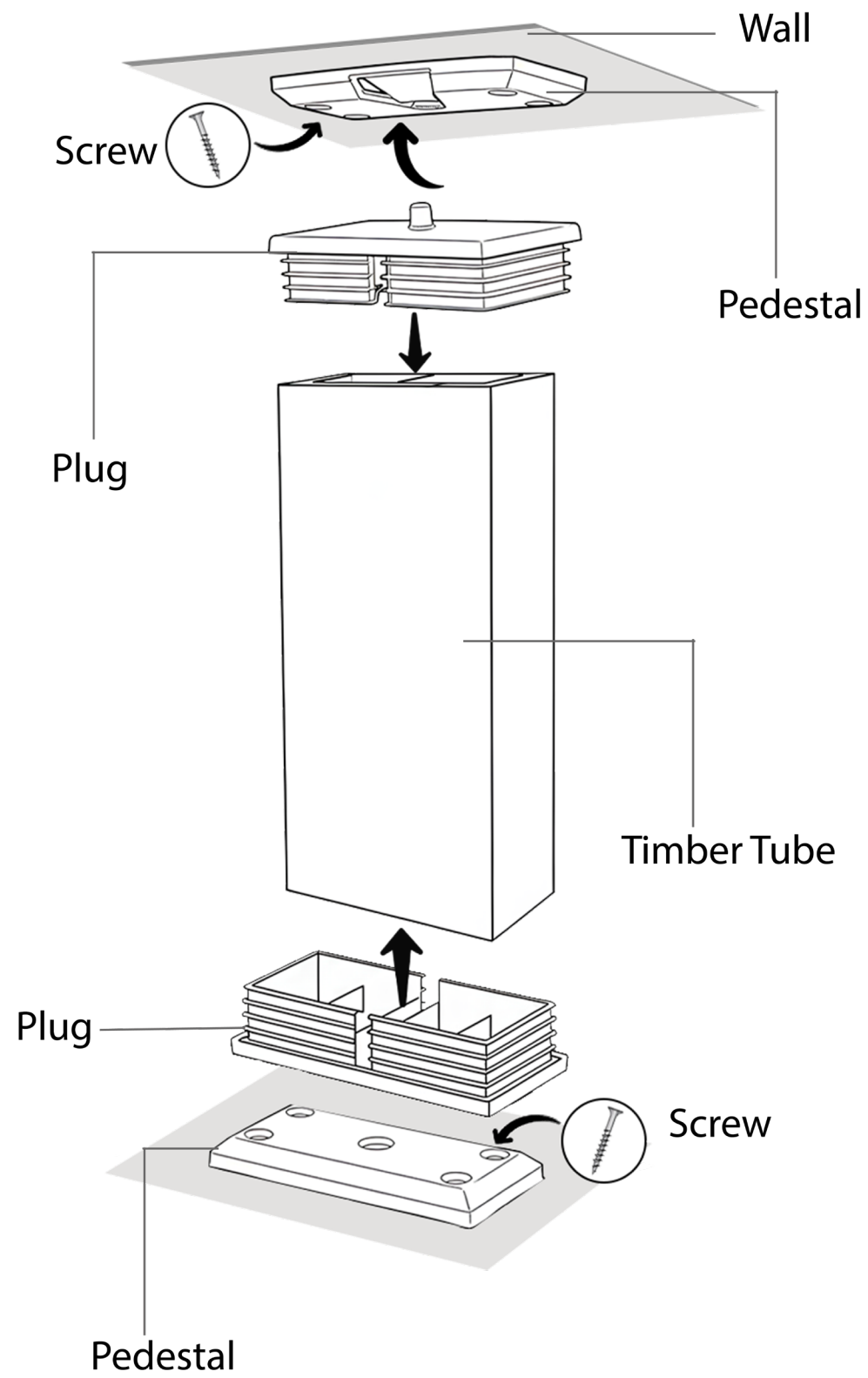



WPC ( Material )



Does not block light  
and airflow



360° Rotation

# | Ceiling installation

The installation of a timber tube ceiling relies on a suspended aluminium profile system for structural alignment. As shown in the diagram, metal L-Clamps are fastened to the side of the aluminium joists and then secured to the Timber Tubes using screws. This mechanical connection ensures precise spacing and stability while accommodating the natural expansion and contraction of the materials.

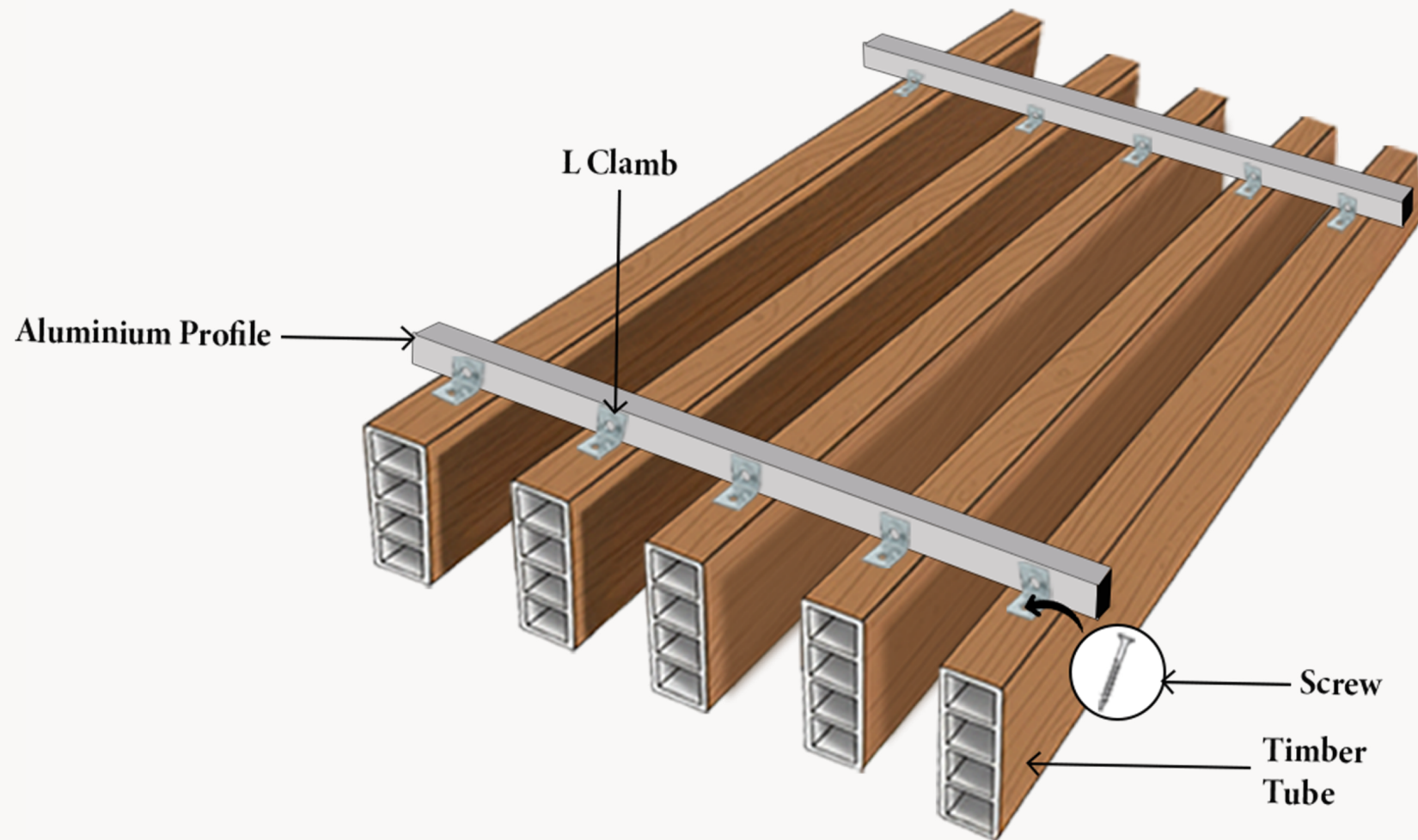

## | Why timber tubes

Adhams Timber Tube is an innovative material designed to replicate the look and functionality of baffle aluminum ceilings while offering the natural elegance of wood. It can be used to create stylish linear ceiling designs in commercial spaces, offices, showrooms, and modern homes. The lightweight yet sturdy structure makes installation easy, while its smooth wooden texture enhances the ambiance with a warm and aesthetic appeal.



## | Uses

Adhams Timber Tube is a durable, lightweight, and eco-friendly alternative to traditional wood. Ideal for furniture frames, interior decor, wall cladding, and ceiling designs, it offers the natural look of timber with greater strength and long-lasting performance.

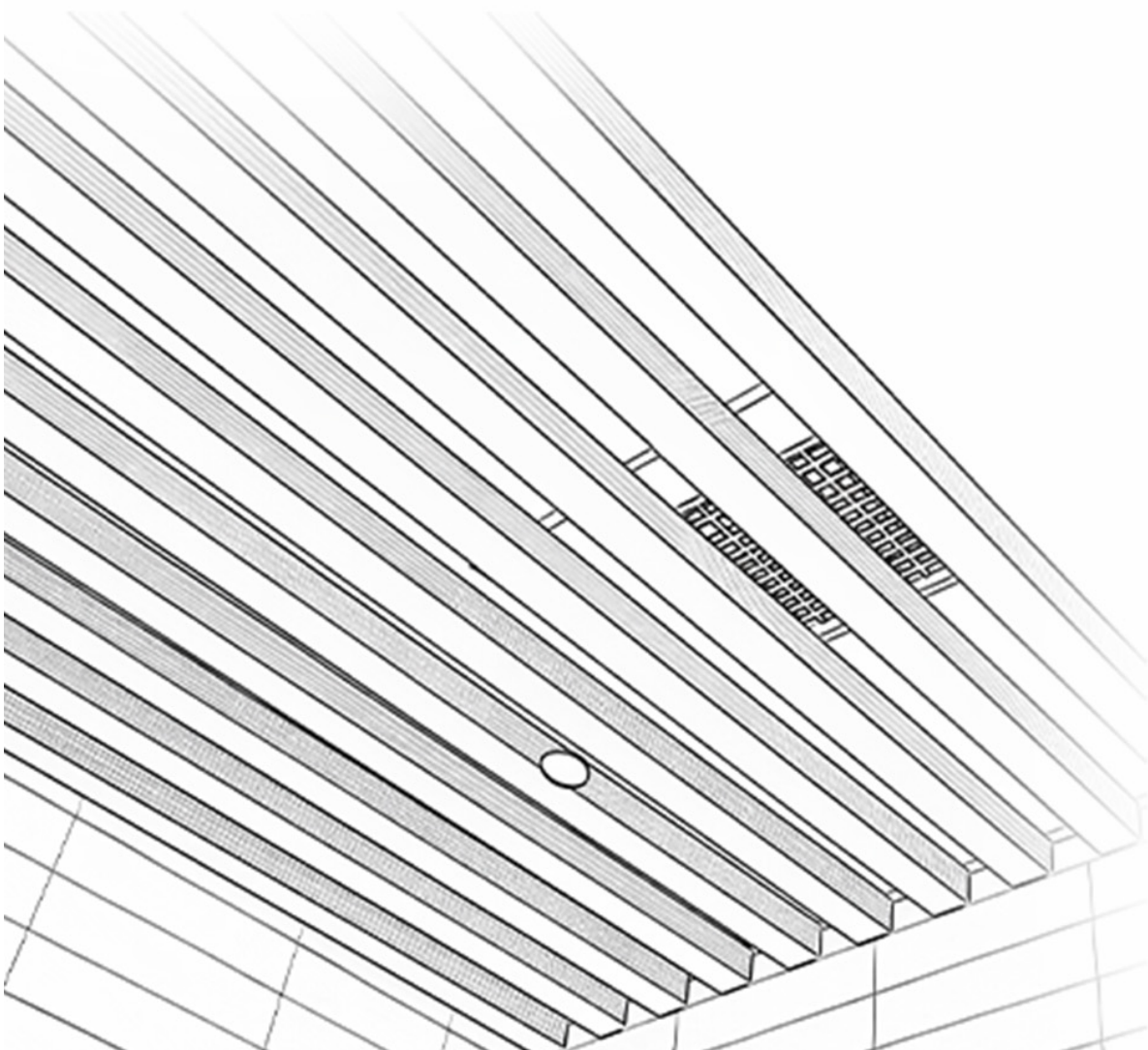

*Thank you*



**Adhams<sup>®</sup>**

Thiruvananthapuram, Cochin, Calicut, kannur, bangalore, Chennai